

# QUEENSLAND P76 OWNERS CLUB INCORPORATED

P.O. BOX 343  
CARINA 4152

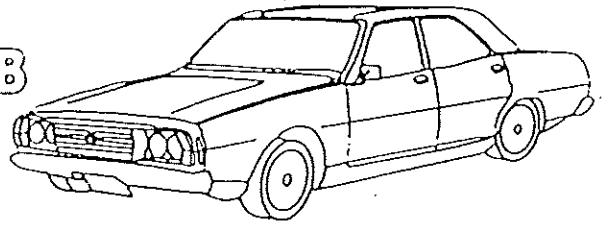

## November 1995

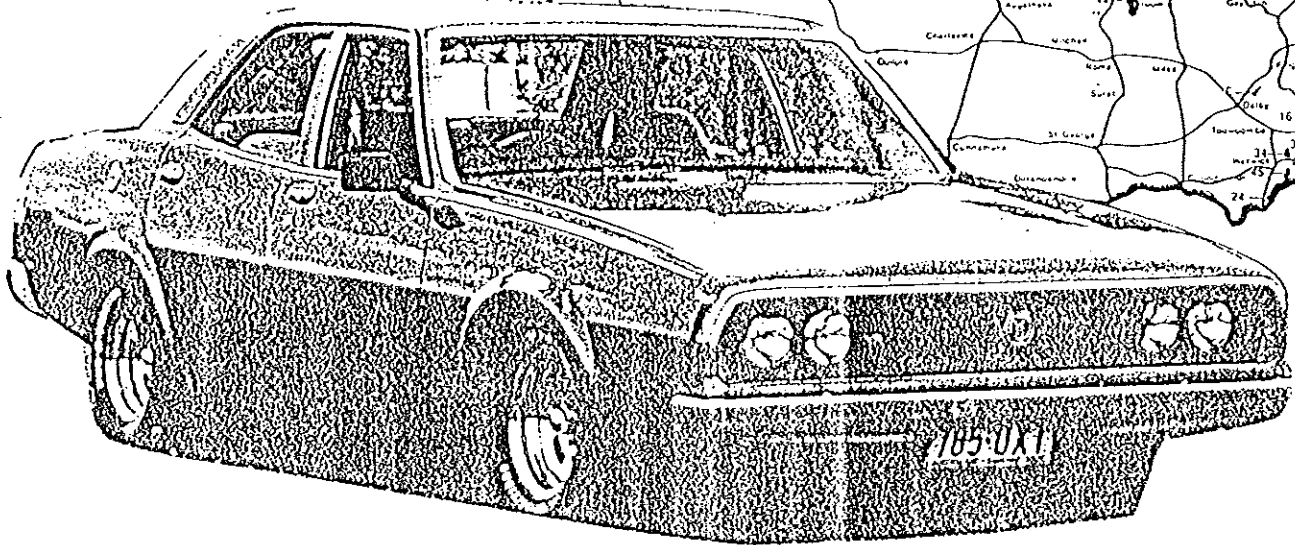
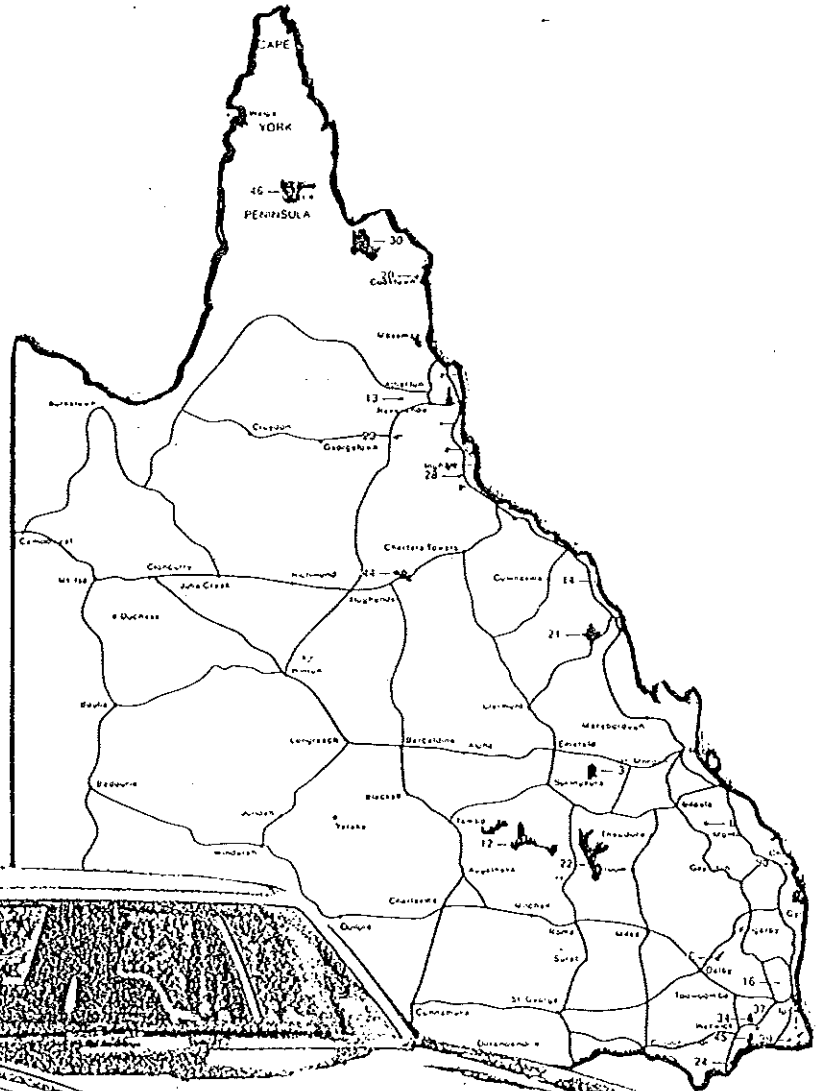
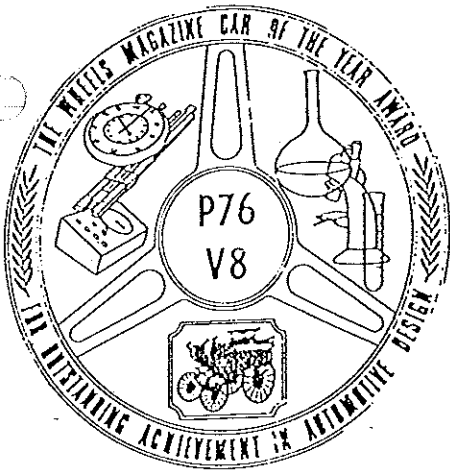

### P76. Anything but average

## NOVEMBER MINUTES

The President opened the meeting at 8.00p.m.

Attendance as per attendance book.

Apologies - Alan Wildman - John Wakeman.

Minutes of the previous meeting were read by the secretary and moved as correct by Brett and seconded by Chris.

Treasurer's report - Not Available.

Incoming Correspondence - Mags were recieved from : Leyland Post  
Leylines  
Victoria

Letters : (1). Menus were recieved for the Xmas Party  
(2). A note from the Coal City Car Club covering their car show on November 12th, 1995.  
(3). A note from Workware Direct covering the range of caps and shirts.

Outgoing Correspondence : (1) Brisbane Motor Spares were paid for parts.  
(2). M.R. Automotive were paid for parts.

General Business: (1). Graham gave a report on all the parts recently bought by the club.  
(2). Graham gave a report on the recent Motokhana.  
(3). The navigation run on the Gold Coast is all arranged and will be held as per the social calender.  
(4). The Xmas Party is all arranged and will be held as per social calender.

Meeting closed at 9.15 p.m.

*Welcome to new member : G. Huschan who has a one owner V8 Super!*

## EDITORIAL

Almost the end of the year. Don't forget to book for the Xmas luncheon on 3rd December at The Sth Acacia Ridge Leagues Club. time 1-00 pm.  
I have printed a copy of the suggested menu to tempt you

Also printed is an update of the financial members as of 12th November 1995.

Also a list of the parts we have just purchased.

We have an interesting report on the Mobil Rally and Hal and Daves efforts courtesy of The Classic Car Monthly.

Do you wonder why there seem to be too many lines on the oil dip stick? The reprint from The Leyland Service Bulletin may help to clear this up.

Brett Shaws observation run on the Gold Coast is all set to go. B.Y.O. Bar B Q and navigator. Hope to see some new faces there.

PLEASE PLEASE LET ME KNOW IF YOU ARE COMING TO THE CHRISTMAS LUNCH AS WE NEED NO'S FOR THE CATERING.

See you this weekend

PAT

---

## ROGO RAVES

Hi Rogo again, Just a quick Rave this month, as usual Pat is waiting to get this in the mag.

A top day was had by all who attended the Motokhana at Ningi, We certainly had a lot of good drivers taking part, and a few not so good. We had a bit of rain which helped to lay the dust, and also made it interesting. I think we will be doing it again next year. This was a trophy event, and this will be presented at the Christmas luncheon.

Plenty of parts were purchased by the club last month. mostly second hand but some new. We have a brand new Flex Plate V8 New set of front park light surrounds. New bumper bars front and rear. New Tow bar. Original Torsion Bar Bushes. Plenty of oil filters. We also have Key Rings @ \$5-00 each. These are just a few of the items we have, so if you want anything just give me a call.

One bit of bad news came to me this week. Neville Humpherys had a serious accident in his P. He came out of it with bruising, but his sister is still in the Nambour hospital with a fractured pelvis. will keep you informed on her progress,

Will see you all at the observation run next sunday. and then at the Christmas luncheon on 3rd December. Remember we need numbers for the catering, so please ring as soon as possible.

keep on P'ing

ROGO

## SOCIAL CALENDAR

November 26th 9-00am

Observation Run on the Gold Coast.

Brett Shaw has put a lot of time into organising this event so hope to see plenty of entrants.

The starting point is Arthur Earle Park Nerang, at 9.15 am  
Finish:- McIntosh Island (Indy Pit Lane)

B.Y.O. Lunch. There are free Gas Bar B Qs, Covered childrens play area. The beach is 50m away. Toilets and showers.

What you will need:- U.B.D. Navigator and patience.

Anyone wishing to form a Convoy to travel to the Coast, ring Graham on 3888 1345.

December 3rd

Christmas break up luncheon,

South Acacia Ridge Leagues Club. Mortimer st Acacia Ridge.

Due to the success of a lunchtime break up last year we have booked for a luncheon at the above venue.

All those members will be subsidised \$10-00 per head, including wife or partner. However guests are welcome but will pay full price for their meal.

There is a good choice of fare which I will reprint to tempt you.

As per usual there will be no Wednesday meeting in December. After the Christmas lunch The next meeting will January 10th 1996.

Any suggestions for next years Social Calendar please ring me on 3888 1345.

So far we are planning a trip to Blackbutt on March 2nd for The Blackbutt State School, to help them celebrate their Education Centenary, The theme is past to present, and several car clubs have been invited to join with them.

March 2nd is a Saturday so we possibly will be travelling on Friday afternoon to be ready nice and early on Saturday.

There will be an award for the best presentation of Car clubs.



SET MENU

- NUMBER 1: MAIN COURSE ONLY \$15.00  
(includes bread rolls, tea/coffee)
- NUMBER 2: ENTREE OR DESSERT AND MAIN COURSE \$22.00  
(includes bread rolls, tea/coffee)
- NUMBER 3: ENTREE, MAIN COURSE AND DESSERT \$28.00  
(includes bread roll, tea/coffee)

CHOOSE FROM OUR SELECTION OF DISHES BELOW

ENTREE

- PATE WITH MELBA TOAST  
CAESAR SALAD  
PRAWN COCTAIL  
MUSHROOMS KILPATRICK  
CAJUN CHICKEN STRIPS WITH GARLIC YOGHURT SAUCE  
AVOCADO SEAFOOD  
SMOKED CHICKEN SALAD WITH BERRY VINIAGRETTE  
CHICKEN AND ASPARAGUS VOL AU VENT

MAIN COURSE

(served with vegetables)

- CHICKEN KIEV  
VEAL SCALLOPINI WITH MUSHROOM SAUCE  
ROLLED RIB ROAST WITH NUT STUFFING AND RED WINE SAUCE  
NUT ENCRUSTED FISH SERVED WITH LEMON BUTTER  
CAJUN CHICKEN BREAST WITH RICE  
FETTUCCHINE CARBONARA  
PORK MEDALLIONS IN SEEDED MUSTARD CREAM SAUCE  
CHICKEN PRINCESS BREAST FILLED WITH ASPARAGUS AND  
CHEESE.

DESSERTS

- CHOCOLATE BASKETS - FILLED WITH CHOCOLATE MOUSSE SERVED ON A STRAWBERRY COULIS
- PAVLOVA - SERVED WITH FRESH WHIPPED CREAM AND FRUIT
- BLACK FORREST GATEAU: - SERVED WITH WHIPPED CREAM
- PECAN PIE - SERVED WITH WHIPPED CREAM
- FRUIT FLAN - SERVED WITH WHIPPED CREAM
- FRUIT SALAD - SERVED WITH WHIPPED CREAM
- CARROT OR BANANA CAKE - SERVED WITH WHIPPED CREAM
- APPLE PIE OR STRUDLE - SERVED WITH WHIPPED CREAM

(07) 354 2053 Fax: (07) 355 3864

**Vintage Parts & Panels**

Restoration Supplies for the Car Enthusiast  
Vintage to Modern

Wood Street,  
Brisbane 4053

P.O. Box 6095  
Mitchelton Qld 4053

ORISED QUEENSLAND DISTRIBUTOR FOR:-  
PETER JACKSONS OLD RUBBER CO.

**PARTS STOCK INCLUDE**

- Door, Boot & Windscreen Seals
- Bailey Channel & Weather Strips
- Pinchweld & Windlacing
- Clips, Grommets, Pedal Rubbers Etc.
- Rust Repair Panels
- RUBBER KITS

for  
**Vehicles 1920s to 1980s**  
call us for fast efficient service

**RUBBERING**  
Gear Box Mounts  
Leyland P76 73/75  
077 070

**LEYLAND P76!**

Rubber and Steel only.  
Flock coated, gloss face.  
1 metre Length.

216.14



216.033

UNIVERSAL - RUBBER  
STEEL INSERT  
FELT FLOCK FACE  
(COVERS 7/16")  
LENGTH 970MM

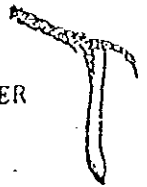

Wiper motor mount  
Set of 3

Price	72.00
Qty	100

238.077

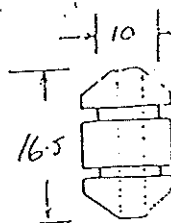

Leyland P76

Horn plate insulator

238.076

P76 Leyland  
Wheel Arch &  
Sill Mould



892.272

Leyland  
P76  
Windscreen  
Mould clip



892.529

NEW

2	V8 Engine Mounts	20-00
1	Gear Box Mount	50-00
2	Universal joints	10-00
1	V8 Flex Plate	150-00
3	Rear Light surrounds	20-00
2	Bumper Bar Ends	10-00
1	Front Bumper Bar	50-00
1	Rear Bumper Bar	50-00
1	Tow Bar	50-00
1	Thermostat V8	5-00
1	Set Front Brake Pads	10-00
1	Sway Bar Bushes	50
8	LE103 Condensor	2-00
1	Set Rear Brake Shoes	12-00
1	Oil Filter	12-00
1 Pr	Front Indicator Surrounds	50-00 pr
1	Speedo Cable	50-00
USED PARTS		
2	V8 Auto Gear Boxes	150-00
57	DeLuxe Hub Caps	7-00
1	V8 Alternator	10-00
1	V8 Radiator Auto	20-00
1	Torque Convertor	30-00
1	V8 Starter Motor	50-00
2	Distributor caps	5-00
1	V8 Water Pump	100-00
1	Ignition Switch & Key	20-00
1	Coil	2-00
1	Fuel Pump V8	15-00
1	Rotor Button	2-00
1	Headlamp	2-00
5	Radiator hoses V8	2-00

USED PARTS

2	Rear Brake Drums	8-00
1	Speedo cable	2-00
2	Engine Mounts	10-00
1	T/Bar Shift	10-00
1	Steering Rack	40-00
1	Fuel Tank	30-00
1	Fuel Filter Pipe	5-00
1	Cross Member	25-00
2	Front Struts with discs	65-00
1	V 8 Diff	70-00

1	Dash Surround	5-00	EACH
1	Bearing Housing	20-00	
1	Steering Column	15-00	
1	Rear Lower Control arm	25-00	
1	Light surround Front Left	10-00	
1	light surround front right	5-00	
1	hand Brake	3-00	
2	horns	2-00	
1	dash facia	25-00	
1	wiper assembly	10-00	
1	accelerator peddle	5-00	
1	wiper motor	20-00	
1	Rear light left	10-00	
1	steering boss	2-00	
1	left front indicator unit	10-00	
1	right front indicastor unit	5-00	
4	arm rests	3-00	
4	Super wheel trims	5-00	
1	DeLuxe Grille	15-00	
1	Indicator switch	10-00	
1	Ignition switch & Key	20-00	
2	Headlamps	2-00	
1	wiper switch	10-00	
1	Dipper switch	5-00	
1	Glove Box	5-00	
1	Sway Bar	10-00	

FOR SALE

Radiators	\$60-00	Weather Shields	\$30-00
G L 27 Points	\$12-00	Z 86 Oil Filters	\$12-00
V8 Gasket sets	\$110-00	6 cyl Gasket top only	\$50-00
Brochures per set	\$30-00	Force 7 Gl box Manual	\$ 6-00
Strut Mount Bushes	\$18-00	Console Letter "L"	\$ 2-00
Hand brake cables	\$16-00	Club tee Shirts	\$20-00
Badges	\$ 6-00	Post Cards	\$ 1-00
No Plate Surrounds Pr	\$10-00	Steering Column Bush	\$15-00
Front Windscreens	\$ 165-00		

RUBBER PRODUCTS

Anti Rattle Bonnet/Bootlid	\$5-00 per pr
Wiper Motor Mounts, set od 3	\$8-00 per set
Firewall Grommett .625 x 1.75	\$4-50 each
Firewall Grommett .875 x 1.75	\$4-50 each
Firewall Grommett .625 x 1.625	\$4-50 each

\*\*\*\*\*

\*\*\*\*\*



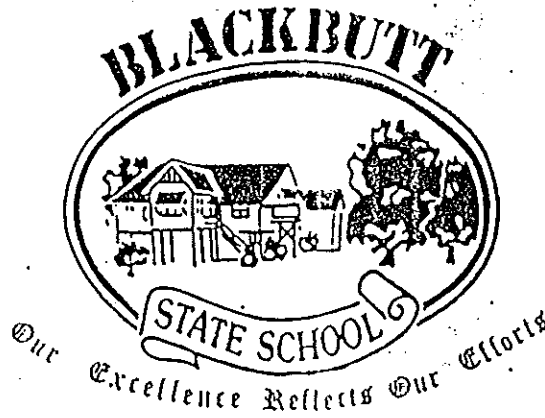

Crofton Street  
BLACKBUTT Q 4306

Telephone: 071-630204  
Fax: 071-630625

5 May, 1995.

Leyland D76 Owners Club Qld  
10 Pindar Street  
ROCHEDALE Q 4123

Dear Sir/Madam,

On 2 March, 1996, the Blackbutt State School will be celebrating its Education Centenary. The highlight of this day will be a street parade with a "Past to the Present" theme.

I would like to invite your club to participate in the parade and also the following festivities on the day.

It is anticipated that assembly time for the parade would be from approximately 10 am and the parade is expected to be over by about 1.30 pm

For your information, Blackbutt is approximately 150 kilometres from the Brisbane GPO in the South Burnett District. Travel from Brisbane is either west from Caboolture or through Ipswich and Esk.

It is intended that if a number of Car Clubs attend, an award would be given for the best presentation.

I will be only too happy to provide further information if you signify your club wishes to attend.

Initial telephone inquiries can be directed to me on 071 630730 outside business hours.

Yours sincerely,

  
Martin Keast  
Blackbutt State School  
Centenary Celebrations Group.

# 1995 Round Australia Trial

We complete our Rally coverage with some entrant's tales

## The surprise of the Trial Hal's rugged P76

Hal Moloney and David Waters  
What a performance from the old Leyland and crew - 17th outright and 2nd in class! Hal's best-ever result and David's first trials' result.

The P76 was possibly the only car in the trial to come through without a major component being changed, and ran a little too embarrassingly close to the top teams for the entire event. Remember, this is a standard bodyshell, no seam welds or added stiffeners, only a roll cage. This car put the reliable back in Reliability Trial, and earned Peter Brock's respect as some of the special stages times posted were better than his. Leyland P76 collectibility must go up after this effort.

Problems encountered along the way were relatively minor - namely one engine mount, two sets of rear shocks - till Chris Dale flew to Perth with Rancho RS9000 adjustables. No more trouble with rear shocks after this. One broken windscreen after clipping a tree at 180kph, rear brake linings changed at Darwin, resealed rear windscreen, minor fuel starvation from reserve tank to main, rear main engine seal leaking, bonnet lock wore out, four sets of headlights and six driving lights (HSV used 53 driving lights). Hal had to be ever-mindful of the fact it was wife Fay's car and had to come home unscathed.

They thought the trial was over for them near Mt Isa when the big Leyland speared off to the left suddenly. Fighting it back to the right, they stopped and examined the left front. The lower control arm had pulled out of the strut, the nut had come off. David, ex-BMC mechanic, took one wheel nut off one wheel, replaced the control arm and screwed it on and back on the road in under two minutes. Good stuff!

Sour-grapes time - our car was given a severe handicap at Townsville Parc Ferme, going into control at 15th position outright. On the way out, they were positioned 39th. After asking the officials present, no one could explain so they had to do a 400km special stage with an extra 24 vehicles in front over a dusty rough stage. This effectively cost first in class as the leading car in class, Falcon GT (104) car, had mechanical troubles this leg. Still no satisfactory answer to this, so how about one official?? Maybe the old car was running too close to the top ten?

Interest from the articles in *Australian Classic Car Monthly* was tremendous



Peter Brock contemplating what might have been if he had chosen to rally in a Leyland P76

along the way - one fellow, Rod Warwick, from Nhill in Victoria, drove 200km just to see the car and talk P76s.

Accommodation along the way was great. Many thanks to Leyland Car Clubs.

The Leyland team support vehicles also had an uneventful and safe trip except for John Bambach in the Land Cruiser, becoming bogged near Nambour on the Nature Strip on the freeway. Caltex fuel, Shell XMO Oil, eight Firestone tyres were used on the way.

An excellent result from a low-budget team. I asked Hal the secret to doing so well and he replied, "First off, a good strong car, then pace yourself to the conditions along the way - much like an adjustable shock absorber, up and down".

After nearly 20,000km, our team missed no controls. Only 26 cars did this,

and 4 hours 19 minutes 14 seconds behind the winner.

Quite an impressive drive in a 22-year-old car, and they will be starters again in the next one - maybe 1999 -

in ... you guessed it ... a Leyland P76.

Brian Blyth



Damage where a suspension nut came off



Windscreen pillar damage



Hal poses proudly with his trophy (2nd in class) and the slightly battered P76

## MEMBERSHIP LIST UPDATED 12/11/95

Adair Graham	Rochedale	3841 5553
Brown Chris	Victoria Point	.....
Buchan Robert	St George	076 255 960
Burton Giles	Slacks Creek	3208 3979
Cammack Bill	Caboolture	074 951 656
Camilleri Vic	Marian	079 543 278
Chu Marcus	Maryborough	076 361 039
Clarke Les	Laidley	074 653 431
Cook David	Bli Bli	074 484 720
Cornwell Chris	Kingston	3808 5433
Coughlan John	Lismore	066 241 717
Dollisson Graham	Crestmead	3805 5630
Elms Mark	Burpengary	3888 4984
Fowke Patricia	Fairfield	3844 2358
Gibbon Andrew	Victoria Point	3207 7533
Hallard Ron	Bundaberg	071 513 851
Hallard Ronald	Bundaberg	071 536 635
Hodgson Pedro	Toowoomba	076 305 136
Holden T. E.	Deagon	3269 3225
Humpherys John	Connondale	074 944 427
Humpherys Neville	Connondale	074 944 427
Huxham Gil	Lutwyche	3857 1317
Jones Reg	Kuluin	.....
Joyce John	Ningi	074 975 389
Kerr Ned	Kandanga	074 843 225

Kirk Tom	Woodridge	3208 8008
Leitch Kenneth	Landsborough	074 94 8631
Lucht Errol & Mary	Dalby	076 623 332
McKenzie Michael	Acacia Ridge	3277 5701
Miller Fred	Yandilla	.....
Morton Pam	Bundaberg	071 599 713
Morton David	England	0602 623 086
Muirhead Russel	Bethania	3200 9643
Murray Colin	Karumba	077 459 192
Nicholson Keith	Capalaba	3245. 6774
Nolan Cyril	Redcliffe	3284 3654
Pearson Don	Kingaroy	071 624 525
Perkins Robert	KippaRing	3284 7791
Peterson Patrick	Blackstone	3282 3520
Preston Robert	Aspley	3350 4589
Rogerson Graham	Narangba	3888 1345
Rose Peter	Rochedale	3341 1229
Schutz Allan	Ipswich	3282 7220
Sear Arthur	Clontarf	3283 1614
Shaw Brett	Carrara	075 596 0936
Shaw Casey	Nambour	074 762 462
Smales John	Maroochydore	.....
Spencer Adrian	Deagon	3269 5644
Spencer John	Victoria Point	3207 7450
Thompson Cedric	MacGregor	3349 2772
Trost Ray	Toowoomba	076 967 364

Wakeman John	Loganholme	3806 0505
Warnock Col	Coffee Camp	066 899 276
Ward Ian	Russel Island	3409 1337
Wildman Alan	Kedron	3357 9696
Wilson John	Highfields	076 968 003
Wilson John	Withcott	076 303 320
Wojtala Adam	Sunnybank	3345 8439
Youlandas John	Lawnton	3882 0189

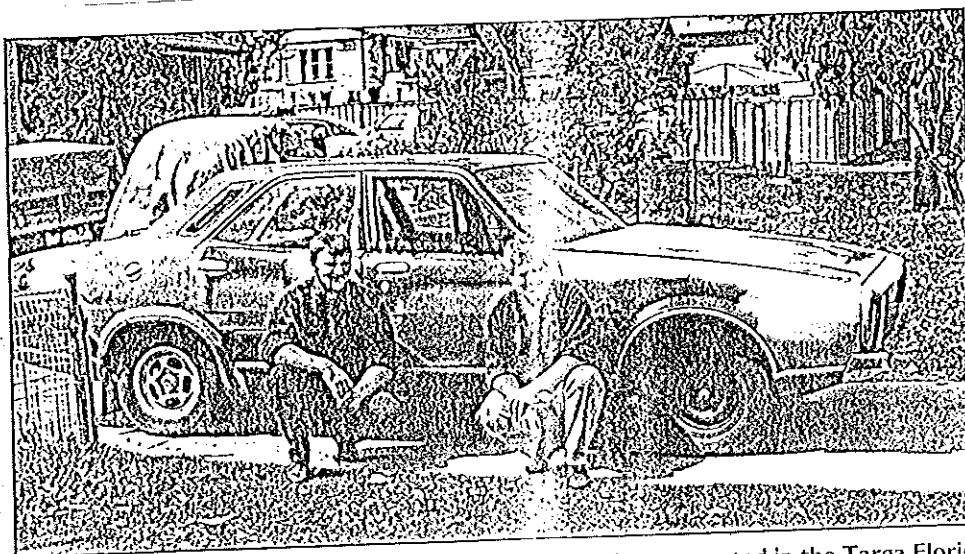

David Waters & Hal Moloney with their '74 P76 which they competed in the Targa Florio

Attention Service Manager



# SERVICE BULLETIN

EXP. 15  
P.S. 12  
P.C. 17  
8.7.1974.  
Sighted by

## TECHNICAL

276 '442' - V8  
and '262' - E6

### ENGINE OIL CAPACITIES

Field reports have been received indicating discrepancies in Engine oil capacities, refill quantities and dipstick graduations.

The following dipstick graduation dimensions and capacity figures are correct.

Dipsticks should not be remarked unless they vary from the dimensions shown.

'442' - V8  
Underside of knob to 'Max' mark.  
475 mm (18.7 in)

'262' - E6  
Underside of knob to 'Max' mark.  
325 mm (12.8 in)

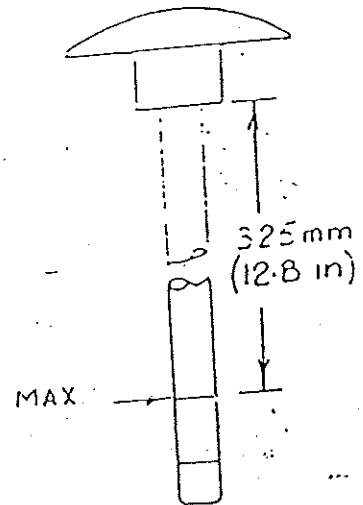
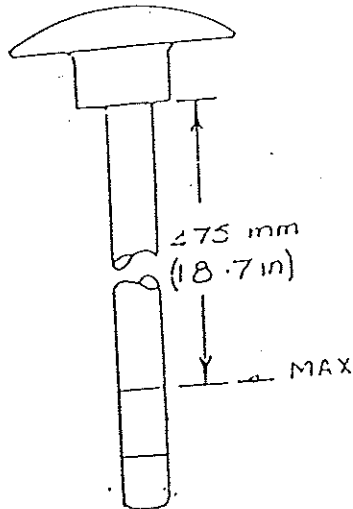

Capacities - '442'  
Drain and Refill  
Oil Filter  
Remaining in Reservoir  
Remaining in Galleries

- 3.0 litres (5.25 pints)  
- 0.74 litres (1.30 pints)  
- 0.57 litres (1.00 pint)  
- 0.57 litres (1.00 pint)

Capacities - '262'  
Drain and Refill  
Oil Filter  
Remaining in Reservoir

- 3.4 litres (6 pints)  
- 0.67 litres (1.36 pints)  
- 0.57 litres (1.00 pint)

LEYLAND AUSTRALIA

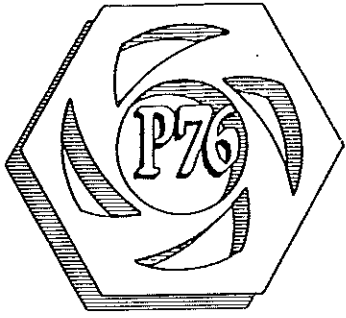

QUEENSLAND P76  
OWNERS CLUB  
INCORPORATED

P.O. BOX 343  
CARINA 4152

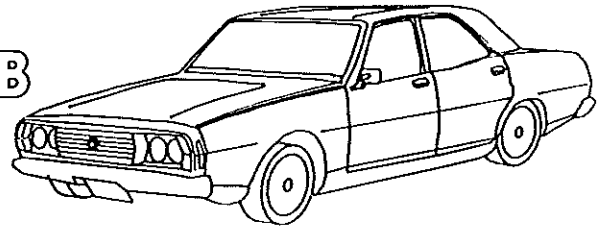

---

# Application for Membership

---

I, ..... hereby apply for full membership to the  
LEYLAND P76 OWNERS CLUB INC. I agree to abide by the rules of the Club and work  
towards the furtherance of the objects of the Club.

Enclosed with this application form is my subscription fee of \$30-00 and my once  
only joining fee of \$10-00.

My address is .....  
.....  
.....Postcode.....

Date of Birth ..... Occupation .....  
Marital Status ..... Phone No. Home .....  
Work .....

VEHICLE DETAILS

	1	2	3
MODEL	.....	.....	.....
V8 OR 6 CYL	.....	.....	.....
COMPLIANCE PLATE	.....	.....	.....
REG. NO.	.....	.....	.....
GEARBOX	.....	.....	.....
COLOUR	.....	.....	.....
MODIFICATIONS	.....	.....	.....
	.....	.....	.....
	.....	.....	.....

Colour Photo enclosed

SIGNED..... DATE.....

FOR OFFICE USE ONLY  
Recommended that this Application be accepted.

CLUB MEMBER ..... DATE .....

CLUB INFORMATION PAGE

YOUR COMMITTEE

PRESIDENT

Graham Rogerson  
635 Old Gympie Road  
NARANGBA. Q. 4504  
PH. 888 1345

VICE PRESIDENT

Neville Humpherys  
Upper Cedar Creek Rd  
CONNONDALE. Q.  
PH. 074-944 427

SECRETARY

John Joyce  
45 Ranald Avenue  
NINGI. Q.  
PH. 074-975 389

TREASURER

Allan Schutz  
10 Cooina St  
EASTERN HEIGHTS. Q.  
PH. 282 7220

EDITOR

Pat Rogerson  
635 Old Gympie Road  
NARANGBA. Q. 4504  
PH. 888 1345

SPARE PARTS

Graham Rogerson  
635 Old Gympie Road  
NARANGBA. Q. 4504.  
PH. 888 1345

\*\*\*\*\*  
This Newsletter is the Official  
Publication of the Queensland P76  
Owners Club Incorporated and is  
issued free of charge to financial  
members. Any opinions expressed  
may not necessarily be those of the  
Editor or the Club, and any  
unintentional defamation or breach  
of copyright herein is unreservedly  
apologised for, and a suitable  
retraction will be inserted in  
the next edition, once the matter  
is drawn to our attention.

GENERAL MEETINGS

The Qld. P76 Owners Club Inc.  
holds its monthly meetings  
on the second Wednesday of  
each month.

TIME: 7.30PM

VENUE: Norman Park Uniting  
Church,  
Cnr. Bennets Road and  
McIlwraith Ave,  
NORMAN PARK.

At the Round-a-bout

\*\*\*\*\*

1995 MEETING DATES

January		11th 1995
February		8th 1995
March		8th 1995
April		12th 1995
May		10th 1995
June		14th 1995
July	AGM	12th 1995
August		9th 1995
September		13th 1995
October		11th 1995
November		8th 1995

\*\*\*\*\*

CLUB OUTINGS

Various activities are  
organised by the clubs  
members and are generally  
held on the fourth Sunday  
of the month. The activity  
and venue will be  
advertised in the monthly  
newsletter.

\*\*\*\*\*

CLUB MEMBER OF THE YEAR

Points Allocated

Attend Meeting	1 point
Raffle Donation	1 point
Organise Event	4 points
Attend Event	2 points
Win Event	1 point