



THE QUEENSLAND  
P76 OWNERS CLUB  
INCORPORATED



Leyland P76. Anything But Average

JUNE/JULY 2005

VOL 9 ISSUE 83

# THE QUEENSLAND BULLETIN



## Toowoomba Visit - 26th June 2005

# YOUR COMMITTEE 2004/2005

## PRESIDENT

GARTH MORRIS  
0417 763 376  
force7@bigpond.net.au



## TREASURER

WARREN ASHWORTH  
07 5535 9311  
ashworth@bigpond.net.au

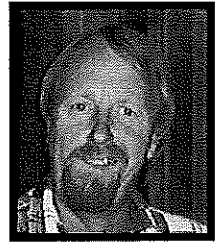

## VICE PRESIDENT

ANDREW GIBBON  
07 3207 4565  
a.gibbon@mailbox.uq.edu.au



## SECRETARY

NEVILLE HUMPHREYS  
07 5494 5565



## EDITOR

LISHA KAYROOZ  
0438 011 550  
lisha\_k@tpg.com.au

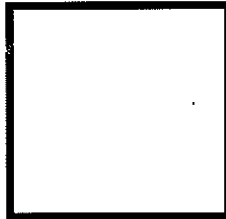

## SPARE PARTS OFFICER

PAT ROGERSON  
07 3888 1345

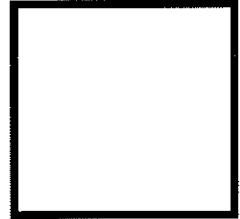

## TECH. OFFICER

GRAHAM ROGERSON  
07 3888 1345

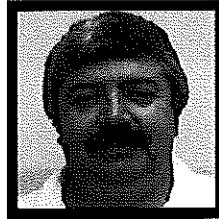

## DATING OFFICER

STEWART HALLS  
07 5598 2697

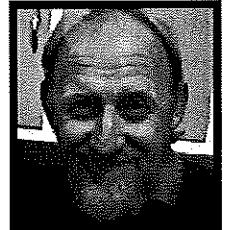

## WEB MASTER & PUBLICITY OFFICER

ADRIAN SPENCER  
07 3314 0058 or mobile 0414 383 503  
Yowee\_98@yahoo.com



## THE QLD P76 OWNERS CLUB Inc.

P.O Box 343  
CARINA QLD 4152  
www.leylandp76.com

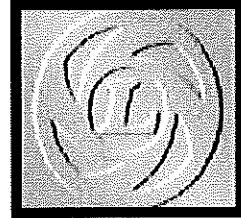

## IMPORTANT NOTICE

### ALL MATERIAL IN THIS MAGAZINE IS COPYRIGHT

Other "P76 Owners" clubs are welcome to reproduce any original material in this newsletter providing mention is made of "The Queensland P76 Owners Club Inc" and the author of that material as the original source.

### CLUB MEMBER OF THE YEAR — POINTS ALLOCATED

Attend Meeting = 1 point : Raffle Donation = 1 point : Organize Event = 1 point : Win Event = 1 point

## **GENERAL INFORMATION**

The Queensland P76 Owners Club Inc holds its monthly meetings on the 2nd Friday of each month at 7.30 PM  
VENUE: Norman Park Uniting Church,  
Cnr Bennetts Rd & McIlwraith Ave  
NORMAN PARK.

Various activities are organized by Club Members and are generally held on the last Sunday of the month. All venue details are confirmed at the General Meeting and are recorded in the Minutes on the next page.

## **WWW.LEYLANDP76.COM**

### MEETING DATES 2005/2006

12th Aug / 9th Sep  
14th Oct / 11th Nov  
9th Dec / 10th Feb 2006  
10th Mar 2006 / 14th Apr 2006  
12th May 2006 / 9th Jun 2006

# JULY 2005 GENERAL MEETING MINUTES



**The President opened the meeting at 8.15 pm.**

Attendance as per Attendance Book.

**Apologies:** Neville & Adrian

**Treasurer's Report:** Balance \$5,326.65

**Incoming Mail:** July Westwords  
Jan/Feb Leyland Post, Mar/Apr Leyland Post  
Invitations to Easter 2006

## **Outgoing mail:**

1. Cheque sent for hall rent.
2. Cheque sent for Trailer rego.
3. Cheque sent to Adrian for food.
4. Cheque sent to Lisha for editorial needs.
5. Cheque sent to Neville to purchase P76.

## **Minutes:**

The minutes of the previous meeting were read by the Secretary.

## **Spare parts:**

1. Bushes have arrived.
2. Gearbox mounts have arrived.

## **General Business:**

1. Discussion on A.G.M. which is next month.
2. Discussion on Club rego. Some members are not attending the two meetings needed to keep club rego. Garth to contact members before reporting to QLD transport.

## **Outings:**

1. 24th July — Clean-up day at Rogos, A lot of parts will be let go to those who attend.
2. 31st July — Outing to Ormeau.

**The meeting was closed at 9.15 pm.**

# PRESIDENTS REPORT

Hello to everyone once again. I must apologise for my lack of presence over the last 2-3 months as I have been busy.

In May I went fishing up in Kakadu & Arnhem Land. Then in April I had to rush to Sydney for my mother-in-law's heart bypass.

For all those that are wondering???? Yes, she still lives.

Hope that everyone had a great time up in Toowoomba last month. I would like to thank Ray & Steven Trost for organizing the day. We had a good turn out and it was a pity that I had to leave so early.

There should be some photos in the magazine of the Toowoomba outing.

Thanks to those that attended last week's meeting and I would like to remind everyone that the next meeting in August is the AGM.

If possible could all those attending please bring a plate of goodies for supper after the meeting.

A few things from the last meeting which need to be passed on to the membership.

Firstly, if you have a P76 on Club Rego then you are reminded that your membership is due, same as everyone else, but if you are not a year ahead then your car is now unregistered. You must be a financial member of the Club to keep your registration. A letter will be sent to the Qld Transport Department with a list of all non-members as of 12th of August 2005. If you have not paid by then, your details will be sent, and your car will be unregistered. This is the obligation that we have to keep with Qld Transport. The other thing is that quite a few of our members that have Club Registration are not attending the two outings or meetings per year. This was an agreement made by the members and the Club when signing up for Club Registration. The newly-elected Committee will decide on what action will be taken at the next meeting.

On to better things. This month has two outings which are listed in the Magazine. This would be a great time to start attending Club outings as the first is a clean-up day at Rogo's. All members attending will be given the chance to take parts that we would normally throw out. So if you want a bargain, be there.

The other outing is the day trip (Sunday 31st July) out to Restorer's Park, Ormeau on the Gold Coast. We have attended before and the day is a great way to look back in time at the old machines that made life a little easier.

Hope to see you all there.

**Garth...**

# Club Outing to Toowoomba – 26 June 2005

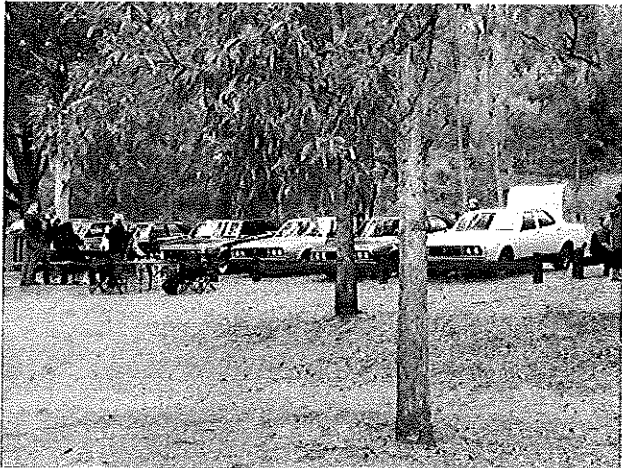
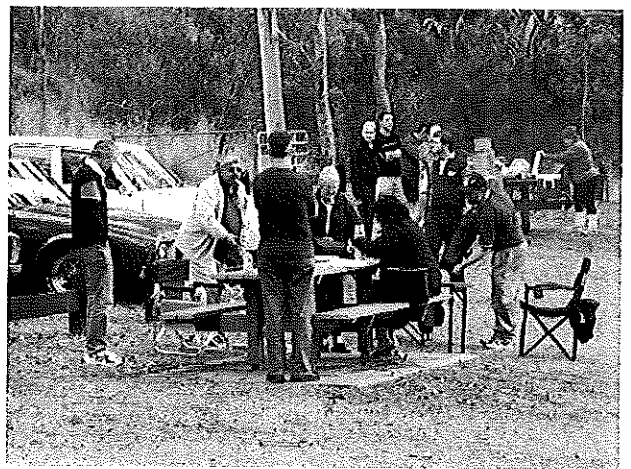
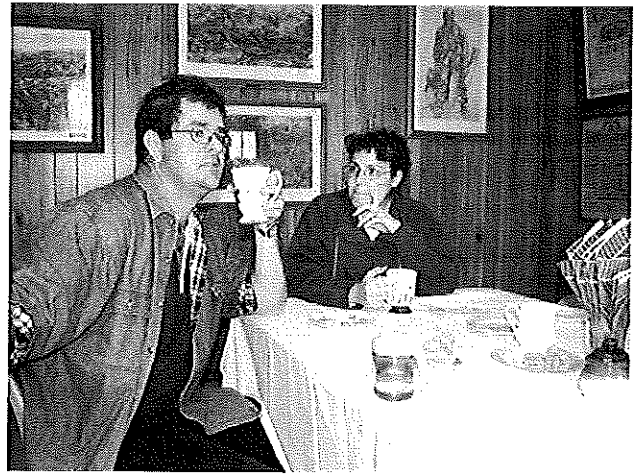

# Darryl Packham's Restoration

Reproduced with permission of the owner.

**Brief History:** Darryl's website is currently down but he has given me permission to publish these pics from it.

The pics that follow show the rotisserie that he built so that he could work on his restoration project from all angles with ease. You'll have to agree that it is a magnificent piece of engineering. He also sent a pic of a simple yet very strong V8 engine trolley. Hopefully his website will be back online soon and you can appreciate more of his amazing work.

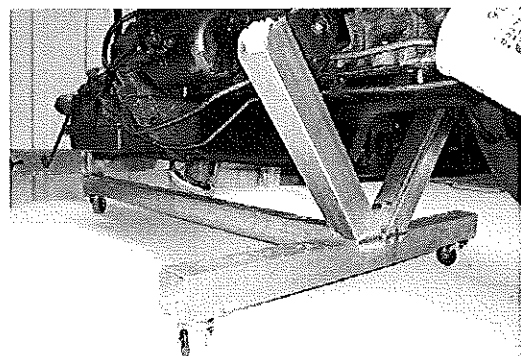
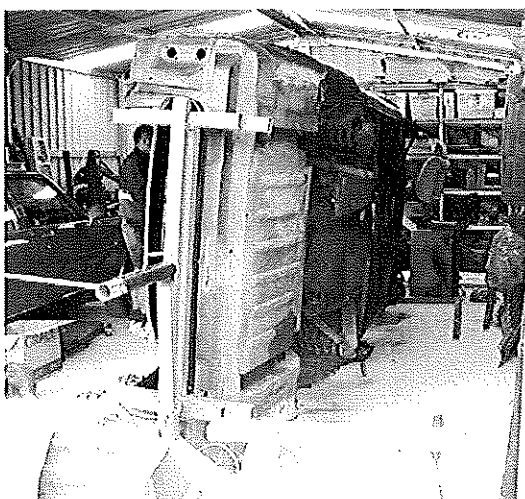
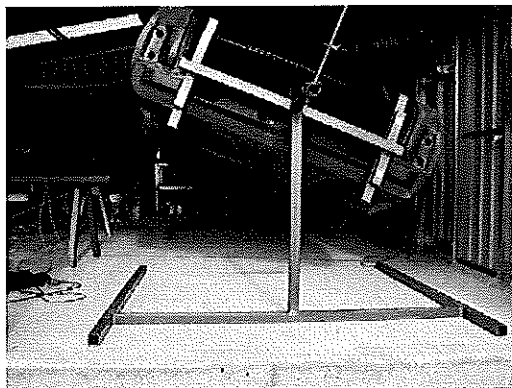
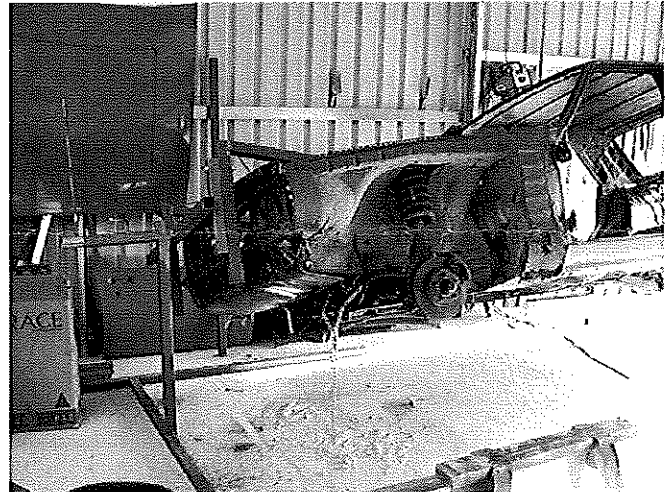
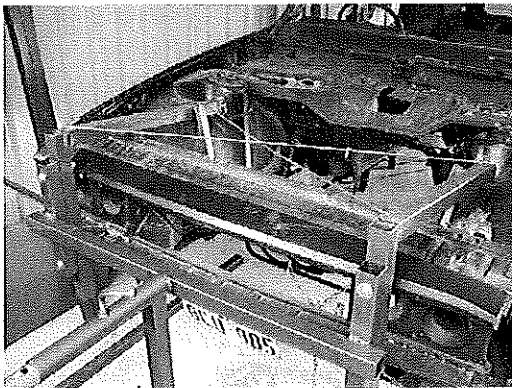

Looking for a little GRUNT ???  
..try *this* in your "P" ...

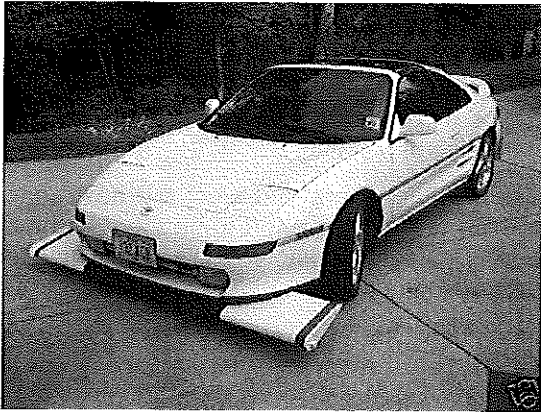

Take a perfectly ordinary looking Toyota MR2..

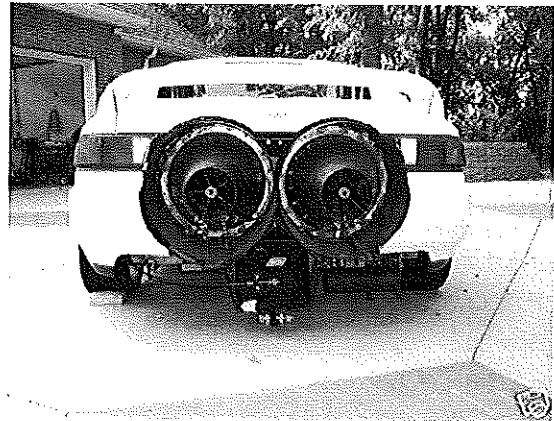

BUT.. stick a couple of *these* babies up the rear

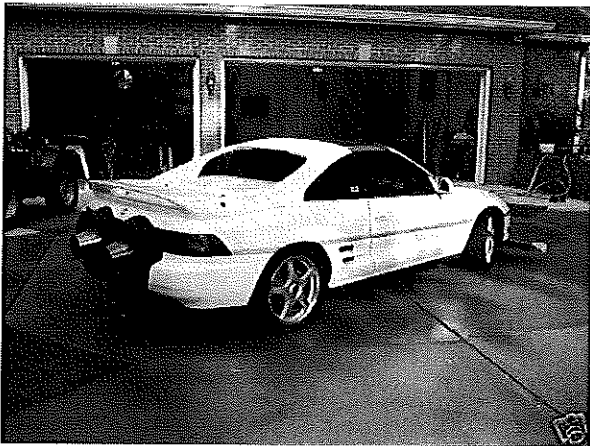

Some people would mistake them for a rather pretentious dual exhaust system

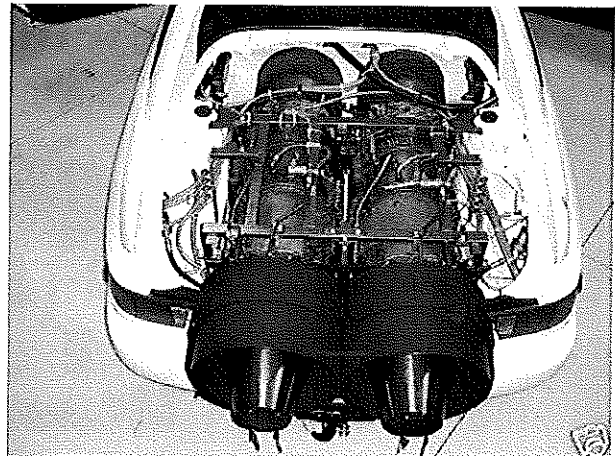

But some people would be **WRONG** !!!!!!!



Notice the two red levers where the gear shift should be ?? Wonder what *they* do ??

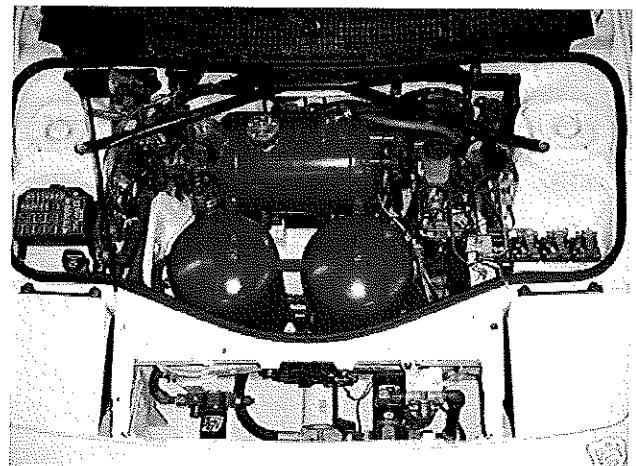

And this is the stuff that runs the whole show.. nothing like my V8 !!

# IMPORTANT CLUB ADMIN

## MEMBERSHIP RENEWALS

As mentioned by Garth in his President's Report, membership subscriptions are now due.

The Renewal form is included with your Bulletin this month. Fill in the details, attach your cheque and send it to:

Qld P76 Owners Club Inc  
PO Box 343  
Carina Qld 4152

## ANNUAL GENERAL MEETING

The next club meeting on Friday 12th August 2005 is the Annual General Meeting.

This is the meeting where you elect the next year's Committee, so make a big effort to be there and take an active part in deciding who you ask to run the club for the coming year.

Two nomination forms are included with each newsletter - if you need more, just photocopy one of these.

*There will be a light supper after the meeting so please bring a plate of munchies to share.*

## More Pics from the Toowoomba Visit

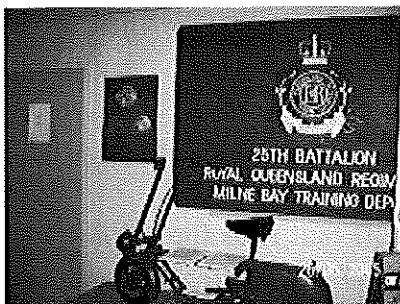





## Editor's Chat Corner

Giddy all -

Time has got away again and with some delays getting part of the contents for the Bulletin, I'm racing to get it into the mail before the outing next weekend (31st July). Having two outings one week apart is a bit of a bugger when you don't know it's coming. So I hope this reaches the non-Internet South-East Queensland members in time to make it to Ormeau.

Can I appeal to all members for some contributions for the Bulletin? Just a few lines on an e-mail or a short letter in the post, would really help get the Bulletin compiled quicker and easier. Without anything to include, apart from meeting minutes, President's Report and pics of the last club outing, that leaves six full pages to fill with interesting stuff. Yes, there is a lot of material around but the club is primarily about *us*.. you and me and our cars. There's nothing more interesting to me than to hear the story of how someone came to have (or keep) his/her car, and all the funny little twists that occurred over the years. So c'mon and help out - let's see something for future issues.

Till next time, safe driving to you all..

Lisha Kayrooz

### A Sobering Thought ...

A father passing by his son's bedroom was astonished to see the bed was nicely made and everything was picked up. Then he saw an envelope propped up prominently on the pillow. It was addressed, "Dad".

With the worst premonition, he opened the envelope and read the letter with trembling hands - it said:

Dear Dad,

It is with great regret and sorrow that I'm writing to you. I had to elope with my new girlfriend because I wanted to avoid a scene with you and mum. I've been finding real passion with Joan and she is so nice. I knew you would not approve of her because of all her body piercing, tattoos, her tight motorcycle clothes and because she is so much older than I am.

But it's not only the passion, Dad... she's pregnant.

Joan said that we will be very happy. She owns a caravan in the bush and has a stack of firewood for the whole winter. We share a dream of having many more children.

Joan has opened my eyes to the fact that marijuana doesn't really hurt anyone. We'll be growing it for us and trading it with the other people in the commune for all the cocaine and ecstasy we want. In the meantime, we'll pray that science will find a cure for AIDS so Joan can get better; she sure deserves it!!

Don't worry, Dad, I'm 15 years old now and I know how to take care of myself.

Someday I'm sure we'll be back to visit so you can get to know your grandchildren.

Your loving son,  
Mick

PS Dad, none of the above is true... I'm over at Tommy's house.

I just wanted to remind you that there are worse things in life than the report card that's in my centre drawer of my desk.

I love you!

...please call when it's safe for me to come home.

## **FORTHCOMING CLUB OUTINGS**

Sunday 31st July – Visit to South Coast Restoration Society - *Pioneer Rally & Craft Display*  
*See enclosed flyer.*

August or Sept – All British Day – more details to come.

November – Topless car run from the Breast Clinic – more details to come.

## **FOR SALE**

Wrecking two Leyland P76's. Both pulled off road at end of last year, but used as daily drivers up till then.  
One body rusty - other one has front-end damage.  
V8 engine and auto \$500  
LPG system - Impeco 300A, converter and 80lt tank (out of date) plus lines and brackets \$200  
100lt LPG tank (tested 07-04) \$200

Located Nambour, Sunshine Coast. Phone Casey Sullivan (07) 5476 2462

From [www.webprom.com.au/p76](http://www.webprom.com.au/p76)

### **Selling 2 cars and spare parts**

Will look at selling cars separately but would like to sell ALL SPARES as a "job lot".  
No fixed prices and open to all "reasonable" genuine offers.

Green car is a 7/73 auto V8 .White car is 1974 6 cylinder manual converted to V8.

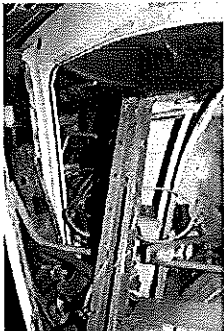
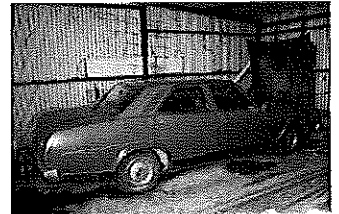

Cars and spares are located on the far north coast NSW within 1 km from Pacific Highway with heavy vehicle access if required.

Contact Graeme on 02 6682 2427,  
mobile 0400 466 972.

